

ISUZU  
mu-X



READY WHEN YOU ARE

# READY FOR ADVENTURE

Introducing the Isuzu MU-X. A seven-seat family SUV that redefines the boundaries of adventure.

## **A new world awaits.**

Whether you're navigating peak-hour on the weekday school run or traversing whatever the wildest weekend can throw at you, the Isuzu MU-X has you covered for the routine, extreme, and everything in between.

Enjoy a passenger car-like driving experience you have come to expect from today's modern SUV's, but with a bulletproof 4WD drivetrain mated to one of the world's most robust diesel engines, the MU-X will deliver you the opportunity to test your off-road ability like never before.

**Isuzu MU-X – Ready when you are.**



# READY TO IMPRESS

## **Bold, adventurous styling.**

The Isuzu MU-X strikes a commanding stance. With suave city-style meshed with tough off-road tones, the MU-X will turn heads for all the right reasons. Available in three different spec levels, there's an MU-X that not only looks the part, but is appropriately designed with all the features required to suit any driving purpose.

Whether your rendezvous is on the red carpet or off the beaten track, the MU-X looks at home in any setting and on any terrain. Effortlessly, the MU-X blurs the boundaries between the city and the outback – providing you and your family an endless choice of exciting destinations.



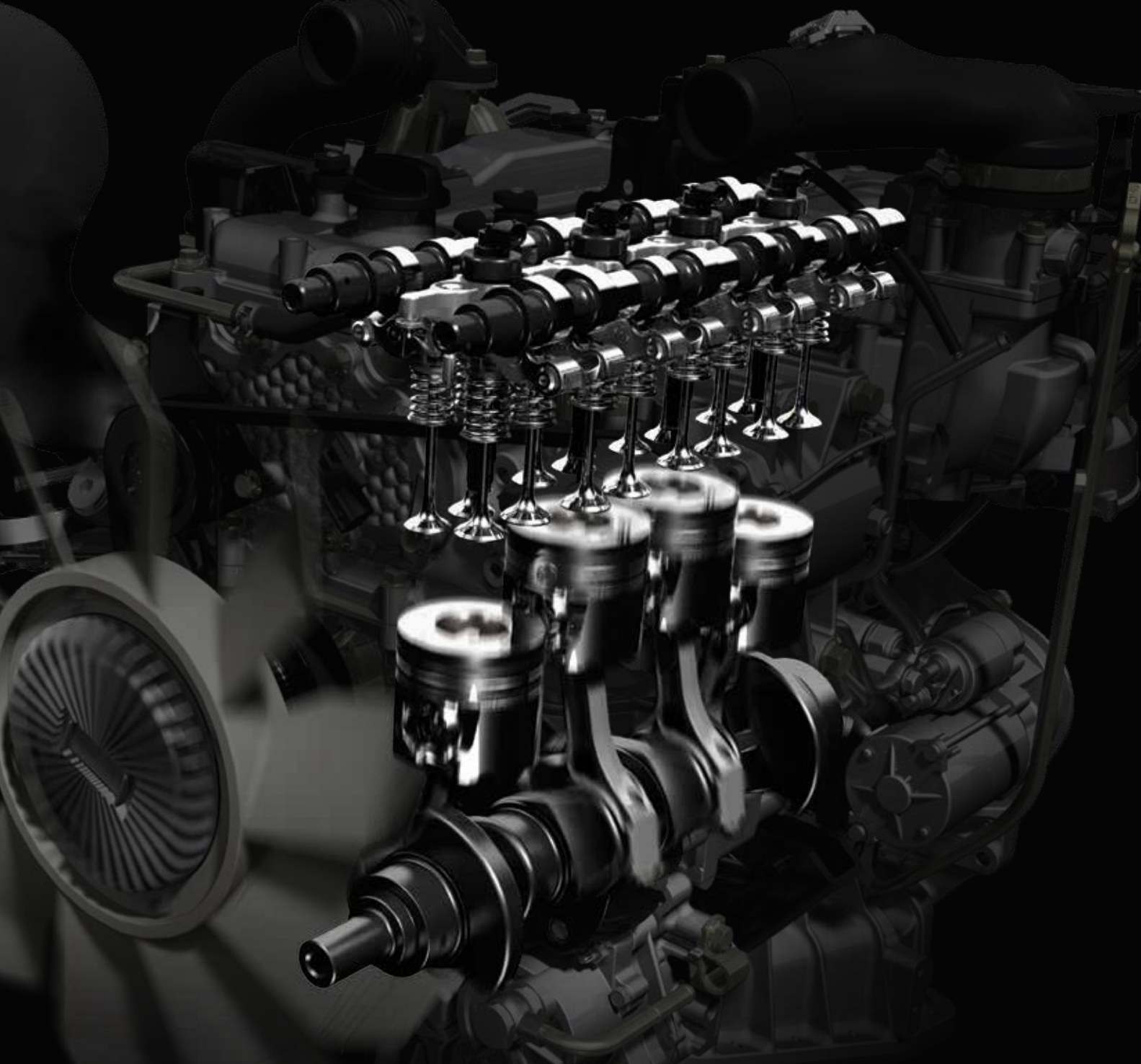

Famous for its durability, reliability and fuel economy, the Isuzu 4JJ1-TC 3.0L turbo diesel engine provides abundant power and torque to make light work of any load

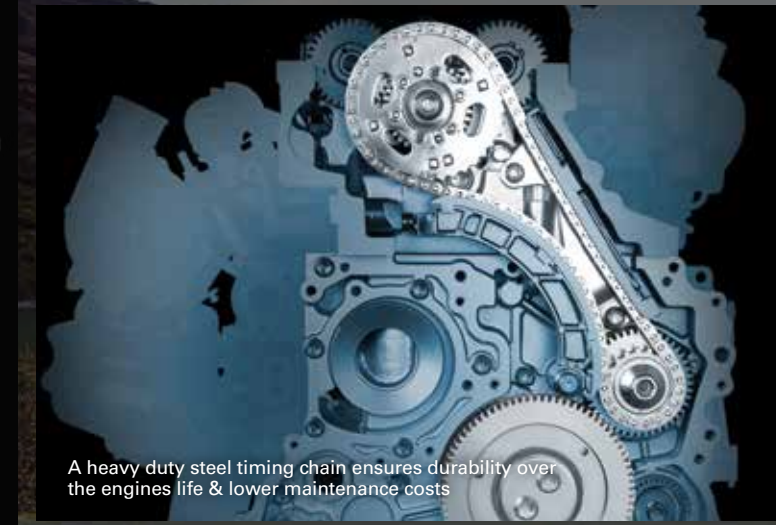

A heavy duty steel timing chain ensures durability over the engines life & lower maintenance costs

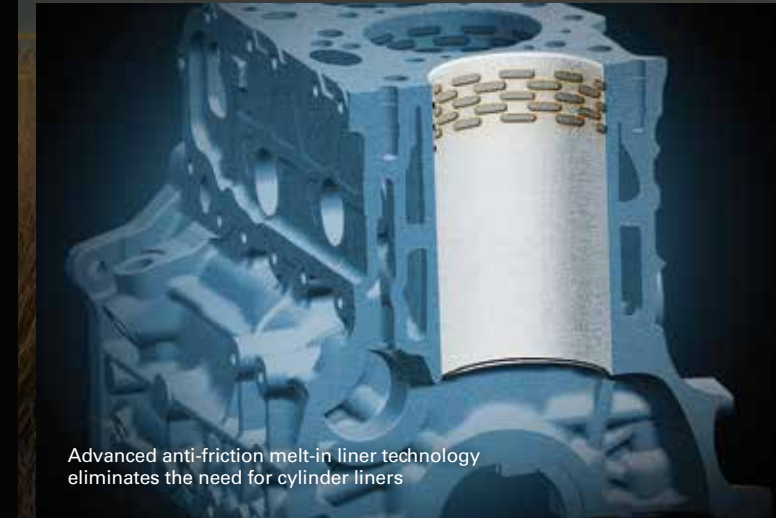

Advanced anti-friction melt-in liner technology eliminates the need for cylinder liners

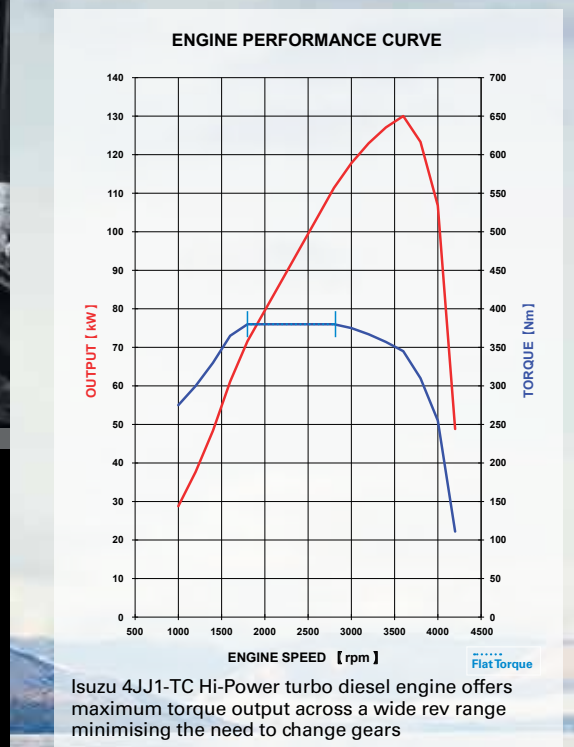

Isuzu 4JJ1-TC Hi-Power turbo diesel engine offers maximum torque output across a wide rev range minimising the need to change gears

# READY TO PERFORM



Behind the style, there's plenty of substance.

With 3 tonne towing (braked) across the entire range, the Isuzu MU-X never knocks back hard work. Be it towing your boat, caravan, horse float or trailer, the MU-X does it effortlessly and with confidence – thanks to the ingenious Isuzu technology and Japanese engineering under the bonnet.

Delivering 130kW of power and 380Nm of torque, the high-pressure common rail fuel injection system makes the most of every drop of fuel, and the intercooled VGS (Variable Geometry System) turbocharger provides excellent response over the engine's entire rev range. Proven in a series of testing environments, each component of the Isuzu diesel engine has been crafted to reduce maintenance and increase durability to ensure years of trouble-free motoring.

4x4 LS-U in Silky White pearl, fitted with extra cost tow bar

Low compression pistons with Teflon coating provide increased fuel economy and engine durability, meaning lower maintenance costs & increased engine life

# READY FOR THE LONG HAUL

## Fuel Consumption Figures

Isuzu MU-X Models	Transmission	Combined Fuel Consumption <sup>Δ</sup>
4x2 LS-M	Automatic	8.1L/100km
4x2 LS-U	Automatic	8.1L/100km
4x4 LS-M	Manual	8.1L/100km
4x4 LS-M	Automatic	8.3L/100km
4x4 LS-U	Manual	8.1L/100km
4x4 LS-U	Automatic	8.3L/100km
4x4 LS-T	Automatic	8.3L/100km



4x2 LS-U in Fjord Blue metallic

### Legendary fuel economy takes you further.

From one of the world's leading manufacturers of diesel engine technology, the impressive Isuzu 3.0 litre turbo diesel engine that powers the Isuzu MU-X is as frugal as it is athletic. Delivering plenty of power and torque, this stirring powerplant produces equally amazing fuel economy from just 8.1<sup>Δ</sup> litres per 100 km – which means less time filling up and more money in your pocket to spend on your next adventure.

The MU-X is as efficient as it gets thanks to three core engine characteristics – low down torque from 1,800rpm through to 2,800rpm provides optimum performance and fuel efficiency, while the MU-X's Variable Geometry System (VGS) turbocharger

alters the direction of exhaust flow to optimise turbine response at low engine rpm to overcome 'turbo lag'. Overseeing the fuel delivery is the MU-X's common rail high pressure fuel system which uses the latest in fuel injector and high pressure fuel rail technology to effectively minimise the amount of fuel in the combustion process, providing superior fuel economy.

In addition, automatic versions of the MU-X also benefit from the intelligent 'grade-logic' transmission which keeps the MU-X in the correct gear preventing over-revving and unnecessary fuel burn.

<sup>Δ</sup>ADR 81/02 is the federal government's standard laboratory based test regime. Figures applicable for MU-X models built from 6 November 2014 onwards. Your figures may depend on driving style, conditions of usage, vehicle condition and load, and other factors.



Common rail high-pressure fuel injection



Fuel efficient 5-speed automatic transmission with Rev-Tronic



Multi Information Display of instant and average fuel consumption

# READY FOR THE TOUGH TERRAIN



4x4 LS-M in Cosmic Black mica, fitted with extra cost accessories

Vehicle clearance and angles dimensions for LS-U and LS-T models

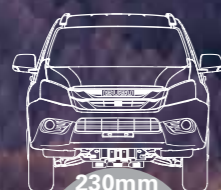

230mm



30.1°

22.6°

25.1°



47°



Underbody protection, front steel plate skid/shield



"Terrain Command" 4WD system allows for simple shift from 2WD high, 4WD high and 4WD low



Independent high ride front coil spring suspension with gas shock absorbers, stabiliser bar, upper and lower wishbones

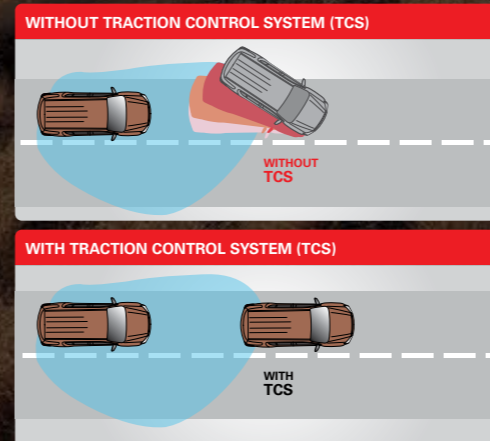

Standard on all models, Traction Control System (TCS) ensures surefooted grip on all surfaces in all conditions

## Four-wheel-drive command at your fingertips.

For years, other manufacturers have been displaying their latest family SUV's traversing rocky mountain ranges and cruising along soft sandy beaches – only to be told in the showroom that "you shouldn't really try that." Well now with the Isuzu MU-X four-wheel-drive you can tackle that always dreamt of destination and reach that out-of-the-way spot with confidence, as it enables you real-world off-road capability.

All 4x4 MU-X models are equipped with Isuzu's super-easy to use "Terrain command" 4WD select dial (2-high, 4-high and 4-low range) with hill-ascent and descent control – so when

the road that takes you to that secret beach, or hidden mountain range gets rough, your spirit for adventure won't be stopped in its tracks.

Every 4x4 MU-X is also fitted with the rugged off-road protection you need when roughing it. There's a front steel plate skid/splash shield as well as steel plate guards to protect the sump and transfer case. Add to this a tried and tested 4x4 drivetrain managed by an intelligent Traction Control System (TCS) with Electronic Stability Control (ESC), along with generous ground-clearance, approach and departure angles – any track is yours to be owned.

4x4 LS-T featuring Charcoal Grey Leather appointed seats\*

# READY FOR THE WHOLE FAMILY



## Interior space and comfort.

Cloaked behind the sleek exterior lines of the Isuzu MU-X lies a smartly designed interior that creates a wealth of space for all of the family – and then some. There's room for you and a team of six to travel safely, securely and in comfort. Wide door arches make access for all passengers a breeze, and when exploring your sense of adventure off-road, there's strategically placed assist grips to help keep you grounded.

In addition to the fun there's also a practical side to the MU-X's interior. There's an abundance of clever storage compartments and with the second and third row seats ability to fold down, there's also an overly generous cargo area when you have a sizeable load to carry. You'll never need to look for another cup

holder again, our design engineers have managed to include 14 of them so you'll always have a refreshment at hand.

A new seat design with 'wrap-around' bolsters provide increased shoulder, back and base support delivering more comfort for occupants. Clever split/fold rear seats in both the second and third rows mean that no matter what seating configuration you choose, the versatile interior will provide you and your family with all the head, leg and shoulder room you need for a relaxing journey.

The Passive Entry and Start System on LS-T models provides convenient cabin access and keyless start operation, making your getaway quick and easy.

\*Leather on body contact areas of seat. Model shown is 14MY MU-X LS-T up to August 2014 production.

Second and third row seats fold flat to allow for maximum load space



Third row seats fold flat to provide extra load space to accommodate 5 occupants



The 40/60 middle seat split design allows for a large load space and 3 occupants



1 seat folds flat to provide extra load space whilst accommodating 6 occupants



Glove compartment (lower) and article storage compartment (upper) with easy access power outlet



Six-way electric driver seat allows you to conveniently find your most comfortable driving position at the touch of a button (LS-T model only)



Map light and roof sunglass holder, offers increased cabin visibility and a convenient storage compartment



The cargo organiser box provides a convenient, safe and organised storage compartment

# READY FOR THE EVERYDAY



Your entertainment needs are at your fingertips with the premium touchscreen audio system, featuring USB, Bluetooth® phone and audio streaming, iPod® connectivity and an inbuilt SAT NAV function (LS-T model only)



The fold-down 10" monitor provides a clear image display, which can be easily viewed by both the second and third row occupants (LS-T model only)



Passive Entry and Start System provides keyless locking and unlocking as well as an engine start/stop button (LS-T model only)



Rear park assist as standard across the range provides increased safety when reversing

### All the mod cons.

While you're having fun behind the wheel, the Isuzu MU-X has also been designed to keep your family entertained.

A premium audio system with 6 speakers, iPod® and Bluetooth® phone connectivity is standard across the MU-X range, while our top of the range LS-T provides an unparalleled entertainment experience with an additional 2 "Sky Sound" roof-mounted speakers and 10" monitor for rear seat passengers. Along with Bluetooth® audio streaming, the LS-T also features a touch-screen satellite navigation system with live traffic updates and over 10,000 off-road destinations to ensure you're always on the right track.

4x4 LS-T automatic featuring sat nav, reversing camera and climate control

Model shown is 14MY MU-X LS-T up to August 2014 production.

iPod® is a trademark of Apple, Inc. Bluetooth® word mark is owned by the Bluetooth SIG, Inc. Not all devices will be compatible and functionality will vary depending on the device.



# READY TO KEEP YOU SAFE

## Peace of mind for everywhere you drive.

Your safety on the road is our priority. To ensure this, the Isuzu MU-X is fitted with the latest in sophisticated safety features. Built around a high-tensile steel passenger safety cell with side-intrusion bars, the MU-X carries comprehensive crash avoidance electronics including 4-channel 4-sensor ABS (Anti-skid Brake System) with EBD (Electronic Brakeforce Distribution) and Emergency Brake Assist (EBA) as well as Electronic Stability Control (ESC) and Traction Control System (TCS). Additional protection and peace of mind is provided with six airbags (dual front, front side and full length curtain). For the safety of those around you, all MU-X models come standard with rear park assist audible sensors and on the LS-T model a reversing camera. These safety features work in unison to give the Isuzu MU-X a five-star ANCAP safety rating across the range.

For the ultimate peace of mind, every MU-X comes standard with a 5 year/130,000km<sup>^</sup> New Vehicle Warranty. This backs up our belief that you will enjoy many years of trouble free motoring as a proud MU-X owner. Isuzu has built a solid reputation of reliability and durability over many generations of vehicles and we have confidence that the Isuzu MU-X upholds this tradition. This warranty is complimentary with every new vehicle and it can even be transferred to the next owner which helps to keep a high resale value for your Isuzu MU-X investment.

Where ever you take your MU-X, you are never alone. Each Isuzu MU-X comes standard with the ultimate in vehicle support, 5 years or 130,000km Premium Roadside Assistance<sup>^</sup>. This complimentary service offers an extensive range of benefits to assist you in the unlikely event you need it.

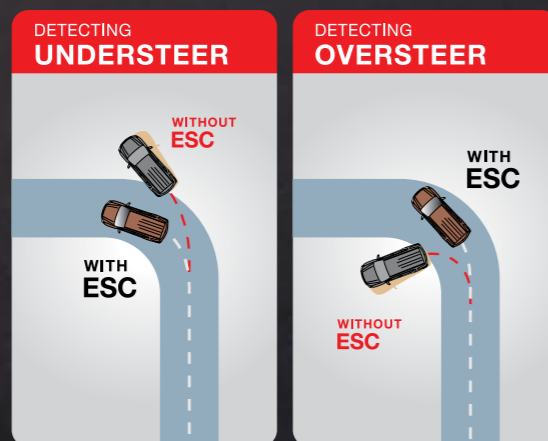

Included on all MU-X models Electronic Stability Control (ESC) detects if the vehicle is under or oversteering



Six airbags – dual front, front side and full length curtain standard on all models

<sup>^</sup>5 years or 130,000km whichever occurs first, for eligible customers; excludes accessories.

# READY FOR YOU

The Isuzu MU-X is offered in three versatile model variants in both 4x2 and 4x4 drivetrains – so there's a vehicle to suit all purposes, be it for your daily grind or family fun.

With a reliable and fuel efficient 3.0L turbo diesel engine, advanced safety features and 3 tonne (braked) towing capacity standard across all models, the MU-X range is always ready when you are.



## LS-M

Our entry-level LS-M is perfectly suited to those looking for a no-nonsense, all-purpose SUV. While stylish for city streets, the LS-M will be right at home on a worksite or farm where the rough-and-tumble of everyday life will be taken in its stride.

**4x2** **4x4**

### LS-M key differentiating features:

---

- 16" alloy wheels with full size spare steel wheel
- All-terrain tyres 245/70 R16
- Colour-coded side mirrors and door handles
- Gun metallic front grille
- Manual air conditioning with integrated heater/demister



## LS-U

The mid-range LS-U is our family all-rounder. The LS-U introduces more of the styling and features you have come to expect from a family SUV, making it the ideal run around during the week with the flexibility to get away from it all when Friday afternoon rolls around.

**4x2** **4x4**

### LS-U key differentiating features:

---

- 17" alloy wheels with full size spare alloy wheel
- Highway terrain tyres 255/65 R17
- Fog lights
- Chrome exterior styling front grille, side mirrors and handles
- Side steps
- Climate control airconditioning with integrated heater/demister
- Rear cabin cooling vents
- Privacy glass - rear doors, quarter and tailgate windows



## LS-T

Our range topping LS-T takes the comfort and convenience levels up another notch. With standard features like leather-appointed seats\*, Passive Entry and Start System, touch-screen navigation, reverse camera and DVD player, every journey will not only be comfortable, but a fun one too.

**4x4**

### LS-T includes all LS-U features plus:

---

- Leather appointed seats\*
- Passive Entry and Start System
- Six-way electric driver's seat
- Roof rails
- Tailgate spoiler
- Chrome muffler tip
- Touchscreen navigation and audio system
- 10" rear monitor display
- Shark fin roof-mounted integrated GPS antenna
- Reversing camera

\*Leather on body contact areas of seat.



**ISUZU**  
**UTE**  
Spirit of Truck

[www.isuzuute.com.au](http://www.isuzuute.com.au) Toll Free: 1300 147 898

This brochure should be read with the Isuzu MU-X specification insert. Isuzu UTE Australia Pty Ltd (ABN 80 129 563 739, 1000 Wynnum Road, Cannon Hill, Queensland, 4170, Australia) reserves the right to change specifications and content without notice, subject to any applicable Federal, State or Territory laws or regulations which may apply. Any accessories shown herein are illustrative and generally are extra-cost optional, not standard equipment. Colours depicted herein may differ from actual due to the printing process. Please refer to [isuzuute.com.au](http://isuzuute.com.au) or consult your authorised Isuzu UTE Dealer for current availability of models, options, specifications, colours and Isuzu UTE Genuine Accessories. No part of this brochure can be reproduced without the written permission from Isuzu UTE Australia. All information is true and correct at the time of publishing, December 2014. Printed in Australia. © Copyright Isuzu UTE Australia Pty Ltd 2014. Part No.: 5463756040 - 15MY MU-X SALES BROCHURE



# ISUZU MU-X | TECHNICAL SPECIFICATIONS

Engine			
Series	Isuzu 4JJ1-TC Hi-Power		
Description	3.0 litre turbo diesel, in-line 4-cylinder, DOHC, 16-valve		
Maximum torque	380 Nm @ 1800→2800 rpm (automatic and manual)		
Maximum power	130 kW @ 3600 rpm		
Bore x stroke	95.4 mm x 104.9 mm		
Displacement	2999 cc		
Compression ratio	17.3 : 1		
Cylinder head	Isuzu-patent special aluminium alloy with double-walled water jacketing		
Valve gear	Chain-driven dual overhead camshafts, roller rockers, 4 valves/cylinder		
Induction	Electronic high pressure common rail direct fuel injection with VSS (Variable Swirl System) & intercooled VGS (Variable Geometry System) turbo charger		
Cylinder block	Cast iron upper with induction-hardened cylinder bores, cast alloy lower; special pistons with nickel composite oil rings		
Emission level	Euro 4		
Alternator	120 amp		
Transmissions			
Manual	Isuzu 5-speed manual with high torque capacity & output reduction 265mm diameter clutch plate		
Automatic	Aisin AW TB50-LS 5-speed with sequential shift & brake shift lock electronically controlled, tri-mode with Adaptive Grade Logic & fuel-saving lock-up torque converter on gears 3, 4 & 5 ▶ Adaptive Grade Logic Control: holds gear in varied-gradient ascents, selects gear on steep descents to hold speed with engine braking ▶ Hill-ascent & hill-descent control		
Ratios: 1		<b>5-speed Manual</b>	<b>5-speed Automatic</b>
	1st	4.332	3.520
	2nd	2.561	2.042
	3rd	1.492	1.400
	4th	1.000	1.000
	5th	0.791	0.716
	Reverse	3.947	3.224
Final drive	4x2	3.727	3.727
	4x4	3.727	3.727
	Snorkelled diff breathers to increase fording depth & reduce mud blockage		
Transfer gearing	4x4 low range	2.482	2.482
	4x4 high range	1.000	1.000
4x4 system	"Terrain Command" control with 'shift on the fly' 2-high↔4-high selection at up to 100km/h		
Drivetrain system	TCS (Traction Control System) & ESC (Electronic Stability Control) on all model variants		

Chassis	
Frame	Separate, full-length heavy-duty ladder construction chassis
Front suspension	Independent, high ride, coil springs, gas shock absorbers, upper & lower wishbones, stabiliser bar
Rear suspension	Multi-link coil suspension, gas shock absorbers, stabiliser bar
Axles	
Front	Independent. 4x4: fully floating with outer CV & inner double offset joints Gross Axle Weight: 1350kg
Rear	Rigid semi-floating banjo with hypoid final drive Gross Axle Weight: 1600kg
Steering	
Engine-speed-sensitive variable capacity power-assisted rack & pinion system; 3.84 turns lock-to-lock via tilt-adjustable steering wheel	
Brakes	
Power-assisted via 10.5" servo unit; 300mm dia ventilated front discs with twin-pot calipers, 318mm rear disc brakes Anti-skid Brake System (ABS) with Electronic Brakeforce Distribution (EBD) and Emergency Brake Assist (EBA) Central pull up park brake	
Wheels & Tyres	
LS-M	16"x 7" alloy; 245 / 70 R16 AT
LS-U, LS-T	17"x 7" alloy; 255 / 65 R17 HT
(Full size spare wheel – alloy on LS-U/LS-T and steel on LS-M)	
Warranty	
5 years or 130,000km whichever occurs first, for eligible customers; excludes accessories.	
	
Please read with current vehicle brochure. All information is true and correct at the time of publishing, December 2014. Isuzu Ute Australia reserves the right to change specifications and features at any time.	

# ISUZU MU-X | FEATURES & SPECIFICATIONS

FEATURES	4x2 Models		4x4 Models		
	LS-M	LS-U	LS-M	LS-U	LS-T
<b>Engine</b>					
2999cc DOHC 4-cylinder, intercooled turbo charged, Euro4, (130kW, 380Nm,)	●	●	●	●	●
<b>Transmissions</b>					
5-speed manual transmission			●	●	
5-speed "Rev-Tronic" automatic transmission with sequential sport mode	●	●	●	●	●
<b>Safety &amp; Security</b>					
4-channel 4-sensor ABS (Anti-skid Brake System) with EBD (Electronic Brakeforce Distribution)	●	●	●	●	●
Electronic Stability Control (ESC)	●	●	●	●	●
Traction Control System (TCS)	●	●	●	●	●
Emergency Brake Assist (EBA)	●	●	●	●	●
6 airbags: dual front, front side and full length curtain	●	●	●	●	●
Reversing camera					●
Rear park assist	●	●	●	●	●
Height-adjustable upper mounts for front seat belts	●	●	●	●	●
Audible and visual front seat belt warnings	●	●	●	●	●
Dual pre-tensioners with load limiters for front seat belts	●	●	●	●	●
3-point retractable seat belts for all seating positions	●	●	●	●	●
Emergency locking retractor (ELR) for all seat belts	●	●	●	●	●
Automatic locking retractor (ALR) for front passenger and 2nd row seatbelts including centre seat	●	●	●	●	●
Three childseat tethers and ISO FIX compatible anchor points for 2nd row seats	●	●	●	●	●
Child-proof rear door locks	●	●	●	●	●
Side anti-intrusion bars inside side doors	●	●	●	●	●
Engine immobilizer	●	●	●	●	●
Anti-theft alarm system		●		●	●
Audible alarm when headlights or parking lights are left on and the key is not in ignition	●	●	●	●	●
Rear window demister with timer	●	●	●	●	●
High Density Polyethylene (HDPE) fuel tank	●	●	●	●	●
High mount LED brake light	●	●	●	●	●
Dual horn	●	●	●	●	●
<b>Protection</b>					
Under-front steel plate skid/splash shield	●	●	●	●	●
Steel plate guards: sump and transfer case			●	●	●
<b>Suspension and Brakes</b>					
Front coil suspension with gas filled shock absorbers	●	●	●	●	●
Rear multi-link coil suspension with gas filled shock absorbers and stabiliser bar	●	●	●	●	●
300mm front ventilated discs brakes with twin-pot calipers	●	●	●	●	●
318mm rear solid disc brakes	●	●	●	●	●
<b>Exterior Style</b>					
Projector lens headlights for extra low beam depth and reduced flare	●	●	●	●	●
Front fog lights		●		●	●
Chrome radiator grille		●		●	●
Gun metal grey radiator grille	●		●		
Aluminium side steps		●		●	●
Chrome door handles		●		●	●
Chrome door handles with touch sensor opening and push button locking					●
Colour-coded door handles	●		●		
Chrome fold-in power door mirrors with integrated turn indicators		●		●	●
Colour-coded power door mirrors with integrated turn indicators	●		●		
Shark fin roof-mounted integrated GPS antenna					●
Roof-mounted bee-sting antenna	●	●	●	●	
Privacy glass - rear doors, quarter and tailgate windows		●		●	●
Roof rails (maximum load capacity 60kg)					●
Enhanced style featuring roof rails, tailgate spoiler and muffler cutter					●

# ISUZU MU-X | FEATURES & SPECIFICATIONS

FEATURES	4x2 Models		4x4 Models		
	LS-M	LS-U	LS-M	LS-U	LS-T
<b>Seating</b>					
Front bucket whiplash protection seats	●	●	●	●	●
Leather appointed seats*					●
Six-way adjustable electric driver's seat					●
Height-adjustable driver's seat	●	●	●	●	
60:40 split-fold 2nd row seats with fold away centre arm rest	●	●	●	●	●
50:50 split-fold 3rd row seats (not available for ISO FIX)	●	●	●	●	●
Adjustable headrests for all seats including centre seat	●	●	●	●	●
<b>In-cabin Storage</b>					
Glovebox with light	●	●	●	●	●
Power outlet in glovebox and in rear cargo area	●	●	●	●	●
Centre console with two cup holders and removable ash container	●	●	●	●	●
Dual-purpose driver and front passenger cup holder tray	●	●	●	●	●
Rear passenger door cup holders	●	●	●	●	●
Overhead console with twin map lights and flip-down sunglasses holder	●	●	●	●	●
Front door storage with cup holders	●	●	●	●	●
Two coat hooks	●	●	●	●	●
Rear cargo organiser box	●	●	●	●	●
<b>Cabin Amenities</b>					
Climate control air conditioning with integrated heater/demister		●		●	●
Manual air conditioning with integrated heater/demister	●		●		
Rear cabin cooling vents		●		●	●
Pollen and fine particle air filter	●	●	●	●	●
Power windows with one-touch down/up, driver's window with safety stop and delay closing	●	●	●	●	●
Central locking with keyless entry	●	●	●	●	
Passive Entry and Start System					●
Power-adjustable door mirrors with turn indicator lights	●	●	●	●	●
Cruise control	●	●	●	●	●
CD/MP3/FM/AM/AUX audio unit with 6 speakers, Bluetooth® phone and audio streaming, and iPod®* plug in via micro USB (cable at extra cost)	●	●	●	●	
DVD/USB/SD/CD/MP3/FM/AM/AUX audio unit with iPod® and Bluetooth® phone and audio streaming (remote control included)					●
*"Sky Sound" roof-mounted sound system - total 8 speakers (front dash, front doors, rear doors and roof)					●
Satellite navigation system with live traffic updates					●
Roof mounted 10" DVD entertainment monitor					●
Reversing camera					●
Rear park assist	●	●	●	●	●
Tilt-adjustable steering wheel with power steering	●	●	●	●	●
Leather wrapped steering wheel with easy select cruise and audio controls	●	●	●	●	●
Multi-Information Display (MID): odometer, trip odometers A and B, fuel economy, range, maintenance distance	●	●	●	●	●
Electro-luminescent gauges	●	●	●	●	●
*"Terrain command" 4WD select dial (2-high, 4-high and 4-low range)			●	●	●
Windscreen wipers with variable intermittent sweep modes	●	●	●	●	●
Rear window wiper	●	●	●	●	●
Day/night interior rear view mirror	●	●	●	●	●
Sun visors with vanity mirror (left) and ticket retaining strap (right)	●	●	●	●	●
Fixed A-pillar assist-grips for driver and front passenger	●	●	●	●	●
Roof mounted retractable door assist-grips for front and rear doors	●	●	●	●	●
3rd row assist-grips	●	●	●	●	●
Carpet flooring	●	●	●	●	●

\*Leather on body contact areas of seat.

\*USB cable at extra cost.

iPod® is a trademark of Apple Inc. The Bluetooth® word mark is owned by Bluetooth SIG, Inc. Not all devices will be compatible and functionality will vary depending on the device.

# ISUZU MU-X | FEATURES & SPECIFICATIONS

SPECIFICATIONS	4x2 Models		4x4 Models		
	LS-M	LS-U	LS-M	LS-U	LS-T
<b>MU-X ADR 81/02<sup>a</sup> Fuel Consumption Values</b>					
Transmission (MT = Manual, AT = Automatic)	AT	AT	MT/AT	MT/AT	AT
<b>FUEL CONSUMPTION (litres/100km)</b>					
Combined	8.1	8.1	8.1/8.3	8.1/8.3	8.3
Urban	10.2	10.2	10.5/10.3	10.5/10.3	10.3
Extra Urban	7.0	7.0	6.8/7.1	6.8/7.1	7.1
<b>CO<sup>2</sup> (g/km)</b>					
Combined	215	215	215/219	215/219	219
Urban	268	268	275/272	275/272	272
Extra Urban	185	185	180/188	180/188	188
<b>Dimensions (mm unless stated otherwise)</b>					
Wheelbase	2845	2845	2845	2845	2845
Overall length	4825	4825	4825	4825	4825
Overall width (excl. door mirrors)	1860	1860	1860	1860	1860
Overall height	1825	1830	1825	1830	1860
Front overhang	905	905	905	905	905
Front / Rear track	1570	1570	1570	1570	1570
Ground clearance - minimum	220	230	220	230	230
Turning circle diameter between kerbs (metres)	11.6	11.6	11.6	11.6	11.6
Approach angle	29.5°	30.1°	29.5°	30.1°	30.1°
Departure angle	24.6°	25.1°	24.6°	25.1°	25.1°
Ramp-over angle	21.9°	22.6°	21.9°	22.6°	22.6°
Fuel tank capacity (litres)	65	65	65	65	65
<b>Interior (mm)</b>					
Leg room - front	1106	1106	1106	1106	1106
Leg room - 2nd	915	915	915	915	915
Leg room - 3rd	815	815	815	815	815
Shoulder room - front	1458	1458	1458	1458	1458
Shoulder room - 2nd	1453	1453	1453	1453	1453
Shoulder room - 3rd	1340	1340	1340	1340	1340
Head room - front	1009	1009	1009	1009	1009
Head room - 2nd	980	980	980	980	980
Head room - 3rd	929	929	929	929	929
<b>Mass (kg)</b>					
Tare Mass <sup>1</sup> (*AT models additional 15kg)	1900	1940	1985*	2025*	2060
Gross Vehicle Mass	2650	2650	2750	2750	2750
Gross Combination Mass	5650	5650	5750	5750	5750
Maximum Towing Mass (Braked Trailer)	3000	3000	3000	3000	3000
Maximum Towing Mass (Non-Braked Trailer)	750	750	750	750	750
Maximum Tow Ball Mass load	300	300	300	300	300

<sup>a</sup>ADR 81/02 is the federal government's standard laboratory based test regime. Figures applicable for MU-X models built from 6 November 2014 onwards. Your figures may depend on driving style, conditions of usage, vehicle condition and load, and other factors.

<sup>1</sup>Tare Mass - unladen mass of vehicle and 10 litres of fuel.

# ISUZU MU-X | MODEL LINE UP & OPTIONS

## MODEL LINE UP

LS-M 4x4 & 4x2 High-Ride



LS-U 4x4 & 4x2 High-Ride



LS-T 4x4



## DIMENSIONS (mm)

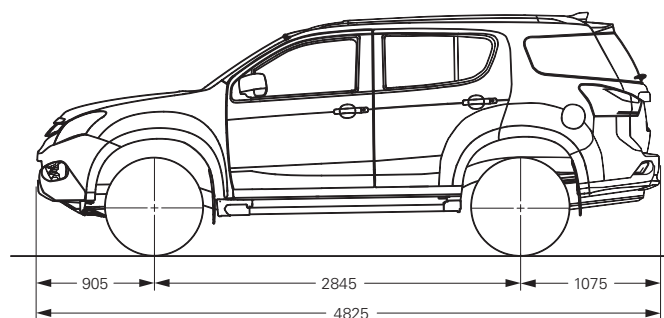
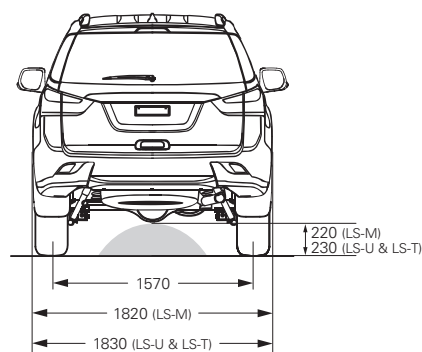
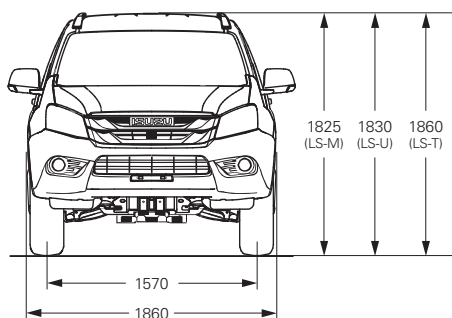

## COLOUR OPTIONS



Titanium Silver metallic



Cosmic Black mica



Fjord Blue metallic



Outback Bronze metallic



Silky White pearl



Splash White

## SEAT TRIMS

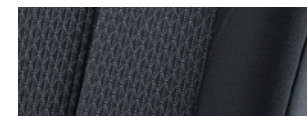

Black Cloth (LS-M & LS-U)

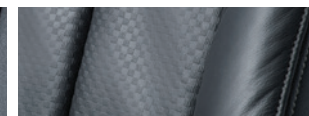

Charcoal Grey Leather\* (LS-T)

Colours depicted herein may differ from actual due to the printing process. Please refer to [isuzuute.com.au](http://isuzuute.com.au) or consult your authorised Isuzu UTE Dealer for current availability of models, options, specifications, colours and Isuzu UTE Genuine Accessories.

\*Leather on body contact areas of seat.